

AOT “DCS” TYPE DRILL COLLAR SLIPS

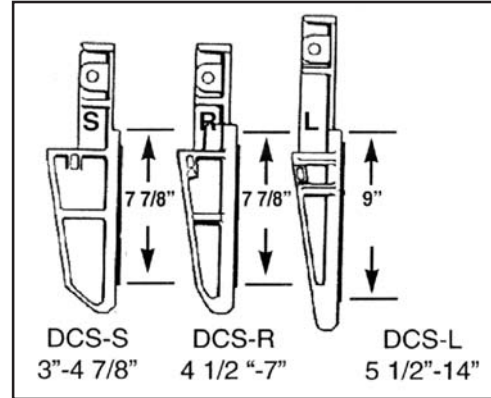

The AOT “DCS” Type Drill Collar Slip has a multi-segment design to give a full wrap-around to insure a proper slip setting. The slips are made of alloy steel and heat-treated for strength and long life.

AOT “DCS” DRILL COLLAR SLIPS COMPLETE

AOT#	DRILL COLLAR SIZE/ SLIP RECESS	TYPE SLIP	REF#	TOTAL SEGMENTS	WT.
16-120	3" - 4"	DCS-S	2572	7	112
16-121	4" - 4 7/8"	DCS-S	2573	7	103
16-122	4 1/2" - 6"	DCS-R	2552	9	120
16-123	5 1/2" - 7"	DCS-R	2550	9	112
16-125	5 1/2" - 7"	DCS-L	2501	11	172
16-126	6 3/4" - 8 1/4"	DCS-L	2503	11	154
16-127	8" - 9 1/2"	DCS-L	2507	12	173
16-128	8 1/2" - 10"	DCS-L	2530	13	185
16-129	9 1/4" - 11 1/4"	DCS-L	2508	14	198
16-130	11" - 12 3/4"	DCS-L	2534	17	213
16-131	12" - 14"	DCS-L	2536	17	207

NOTE: SLIP SIZES 3" - 9 1/2" FOR USE IN API OR #3 BOWL
 SLIP SIZES 8 1/2" - 11 1/4" FOR USE IN #2 BOWL
 SLIP SIZES 11" - 14" FOR USE IN #1 BOWL

ALL PARTS ARE INTERCHANGEABLE WITH VARCO® “DCS” TYPE DRILL COLLAR SLIPS

REPLACEMENT PARTS FOR AOT "DCS" DRILL COLLAR SLIPS

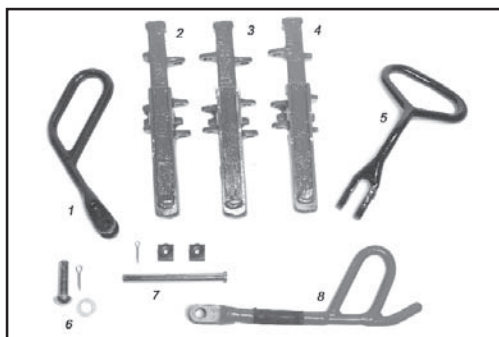

AOT#	ITEM#	DESCRIPTION	* SPARES	SIZE	#REQ.	REF#.	WT.
14-104	1	FRONT HANDLE	2	3" - 14"	2	3765	3.50
16-102	2	LEFT HAND SEGMENT f/DCSS		3" - 4 7/8"	1	2569	11.00
16-105	2	LEFT HAND SEGMENT f/DCSR		4 1/2" - 7"	1	2555	10.00
16-108	2	LEFT HAND SEGMENT f/DCSL		5 1/2" - 14"	1	2511	12.00
16-103	3	INTERMEDIATE SEGMENT f/DCSL		3" - 4 7/8"	5	2570	11.00
16-106	3	INTERMEDIATE SEGMENT f/DCSR		4 1/2" - 7"	7	2556	10.00
16-109	3	INTERMEDIATE SEGMENT f/DCSL		5 1/2" - 8 1/4"	9	2512	12.00
16-109	3	INTERMEDIATE SEGMENT f/DCSL		8" - 9 1/2"	10	2512	12.00
16-109	3	INTERMEDIATE SEGMENT f/DCSL		8 1/2" - 10"	11	2512	12.00
16-109	3	INTERMEDIATE SEGMENT f/DCSL		9 1/4" - 11 1/4"	12	2512	12.00
16-109	3	INTERMEDIATE SEGMENT f/DCSL		11 - 14"	15	2512	12.00
16-104	4	RIGHT HAND SEGMENT f/DCSS		3" - 4 7/8"	1	2568	11.00
16-107	4	RIGHT HAND SEGMENT f/DCSR		4 1/2" - 7"	1	2554	10.00
16-110	4	RIGHT HAND SEGMENT f/DCSL		5 1/2" - 14"	1	2510	12.00
14-103	5	REAR HANDLE	1	3" - 10"	1	3766	4.00
14-103	5	REAR HANDLE	1	9 1/4" - 14"	2	3766	4.00
14-105	6	HANDLE PIN	3	3" - 10"	3	3769	.50
14-105	6	HANDLE PIN	3	9 1/4" - 14"	4	3769	.50
14-106	7	HINGE PIN f/DCSS	4	3" - 4 7/8"	6	2525	.70
14-106	7	HINGE PIN f/DCSR	4	4 1/2" - 7"	8	2525	.70
16-112	7	HINGE PIN f/DCSL	4	5 1/2" - 8 1/4"	10	2520	.70
16-112	7	HINGE PIN f/DCSR	4	8" - 9 1/2"	11	2520	.70
16-112	7	HINGE PIN f/DCSR	4	8 1/2" - 10"	12	2520	.70
16-112	7	HINGE PIN f/DCSR	4	9 1/4" - 11 1/4"	13	2520	.70
16-112	7	HINGE PIN f/DCSR	4	11" - 14"	16	2520	.70
23-112	8	SAFETY FLEX HANDLE	3	ALL	A/R	N/A	4.00

* RECOMMENDED SPARE PARTS FOR 1 YEAR OF OPERATION

BUTTON INSERTS FOR AOT "DCS" DRILL COLLAR SLIPS

AOT#	SLIP TYPE	SIZE	REF#.	WT./SET	QTY.
14-628	DCS S	3" - 4"	2628	13.00	49
14-620	DCS S	4" - 4 1/2"	2620	8.00	49
14-628	DCS R	4 1/2" - 6"	2628	16.00	63
14-620	DCS R	5 1/2" - 7"	2620	11.00	63
14-513	DCS L	5 1/2" - 7"	2513	19.00	88
14-630	DCS L	6 3/4" - 9 1/2"	2630	15.00	88
14-630	DCS L	8" - 9 1/2"	2630	16.00	96
14-627	DCS L	8 1/2" - 10"	2627	26.00	104
14-630	DCS L	9 1/4" - 11 1/4"	2630	19.00	112
14-625	DCS L	11" - 12 3/4"	2625	20.00	136
14-630	DCS L	12" - 14"	2630	22.00	136

ALL PARTS ARE INTERCHANGEABLE WITH VARCO® "DCS" DRILL COLLAR SLIPS
RECOMMENDED SPARE PARTS INCLUDE 2 SETS OF INSERTS FOR EACH SLIP SIZE